

1 - Hood

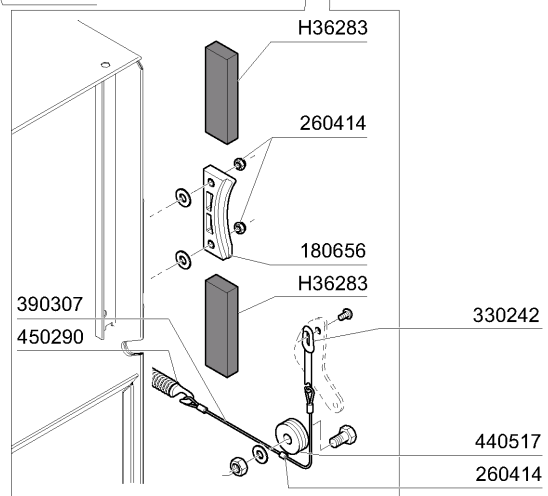
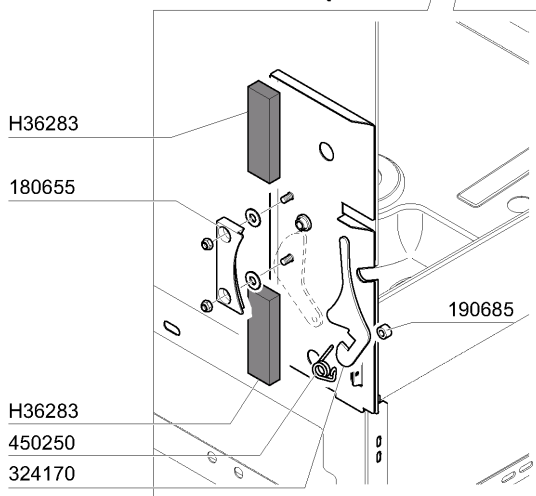
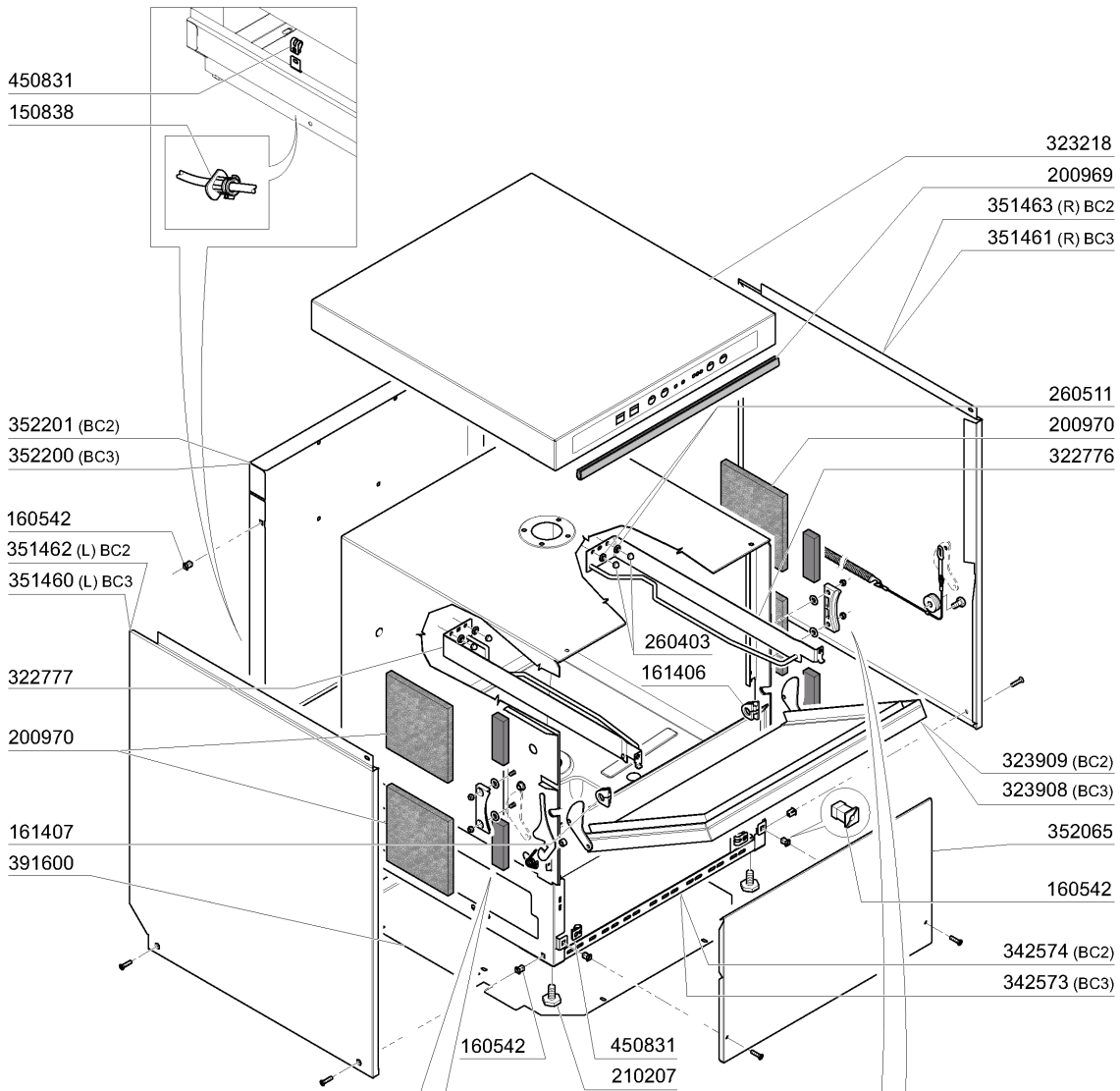

07 - 2010 M. S.

**1 - Hood**

<b>CODE</b>	<b>DESCRIPTION</b>
150838	CABLE HOLDER FOR BHC
160542	SCREW SUPPORT
161406	GOMMINO X CERNIERA PORTA DX
161407	PAD
180655	LEFT GUIDE
180656	RIGHT GUIDE
190685	BUSH
200969	DOOR GASKET BC
200970	JOINT 150X125X10
210207	FOOT BHC
260403	NUTS D.5
260414	SELF-LOCKING NUT M5
260511	GROWER WASHER D.5
322776	RIGHT RAIL LB
322777	LEFT RAIL LB
323218	UPPER COVER BC2/3 E
323908	DOOR BC3
323909	DOOR BC2
324170	BRACKET
330242	TIE ROD
342573	HOOD BC3
342574	HOOD BC2
351460	LEFT SIDE PANEL BC3
351461	RIGHT SIDE PANEL BC3
351462	LEFT SIDE PANEL BC2
351463	RIGHT SIDE PANEL BC2
352065	FRONT PANEL BC
352200	BACK PANEL BC3
352201	BACK PANEL BC2
390307	CABLE
391600	PANEL
440517	ROLLER
450250	SPRING
450290	SPRING
450831	SCREW SUPPORT
H36283	GASKET 20X10

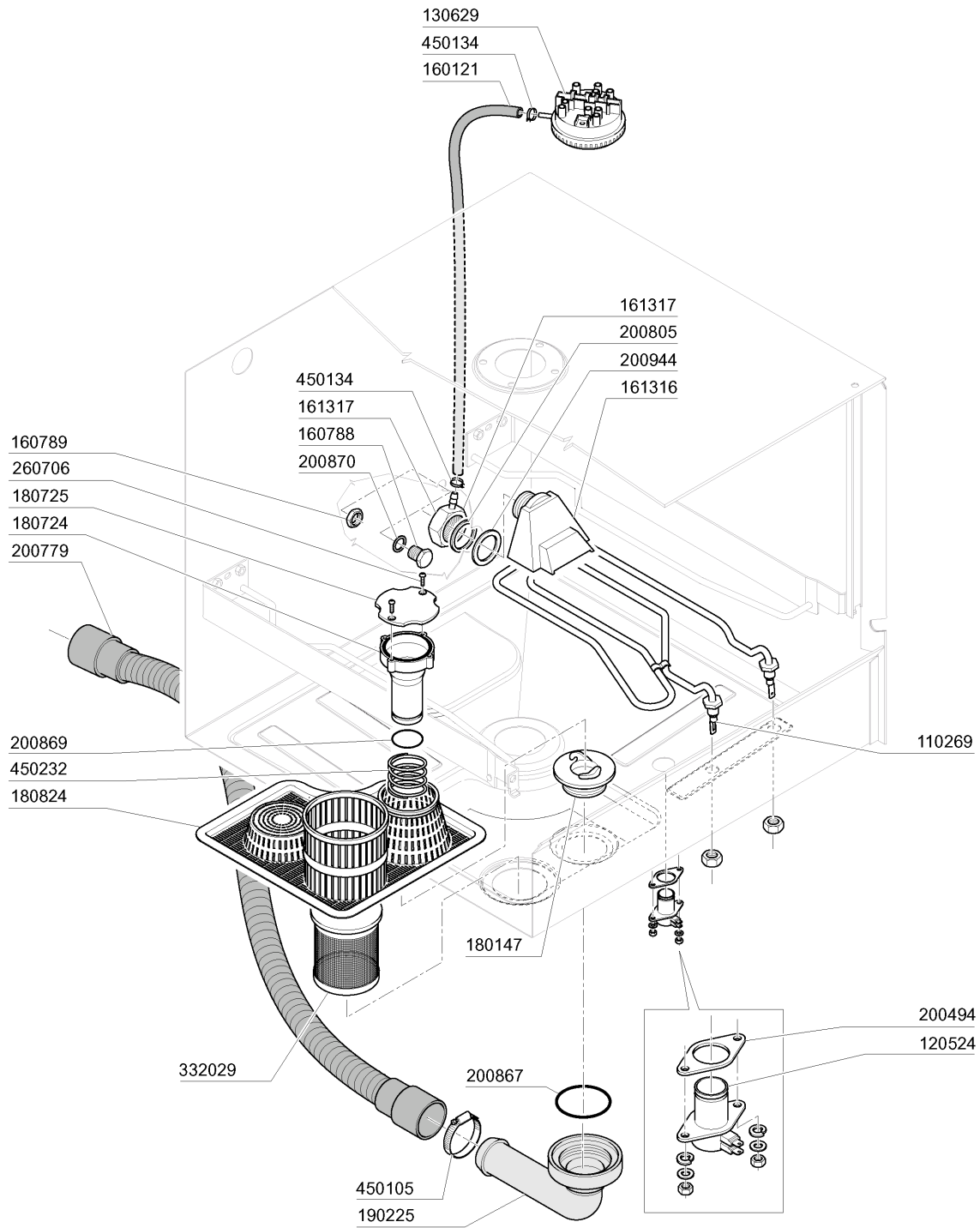

**2 - Tank**

<b>CODE</b>	<b>DESCRIPTION</b>
110269	TANK HEATER 2000W
120524	TANKTHERMOSTAT GLASSWASHER
130629	PRESSURE SWITCH 1L30-12
160121	HOSE EPDM D. 5 X 9
160788	PLUG
160789	NUT
161316	AIR TRAP
161317	NUT FOR AIR TRAP
180147	NUT
180724	OVERFLOW PIPE BHC
180725	OVERFLOW PIPE COVER
180824	TANK STRAINER BHC
190225	DRAIN OUTLET
200494	GASKET FOR TANKTHERMOSTAT BT
200779	DRAIN HOSE FOR BR-BC-FC43
200805	OR GASKET 2,62X28,24X33,48
200867	GASKET
200869	GASKET
200870	GASKET 18X10X2
200944	GASKET
260706	SCREW 3,9X13 S/S
332029	PUMP FILTER BHC
450105	CLAMP FE ZN. 26-38 H=12,2
450134	ELASTIC HOSE CLIP D.9,3/8,8
450232	SPRING

### 3 - Wash Column

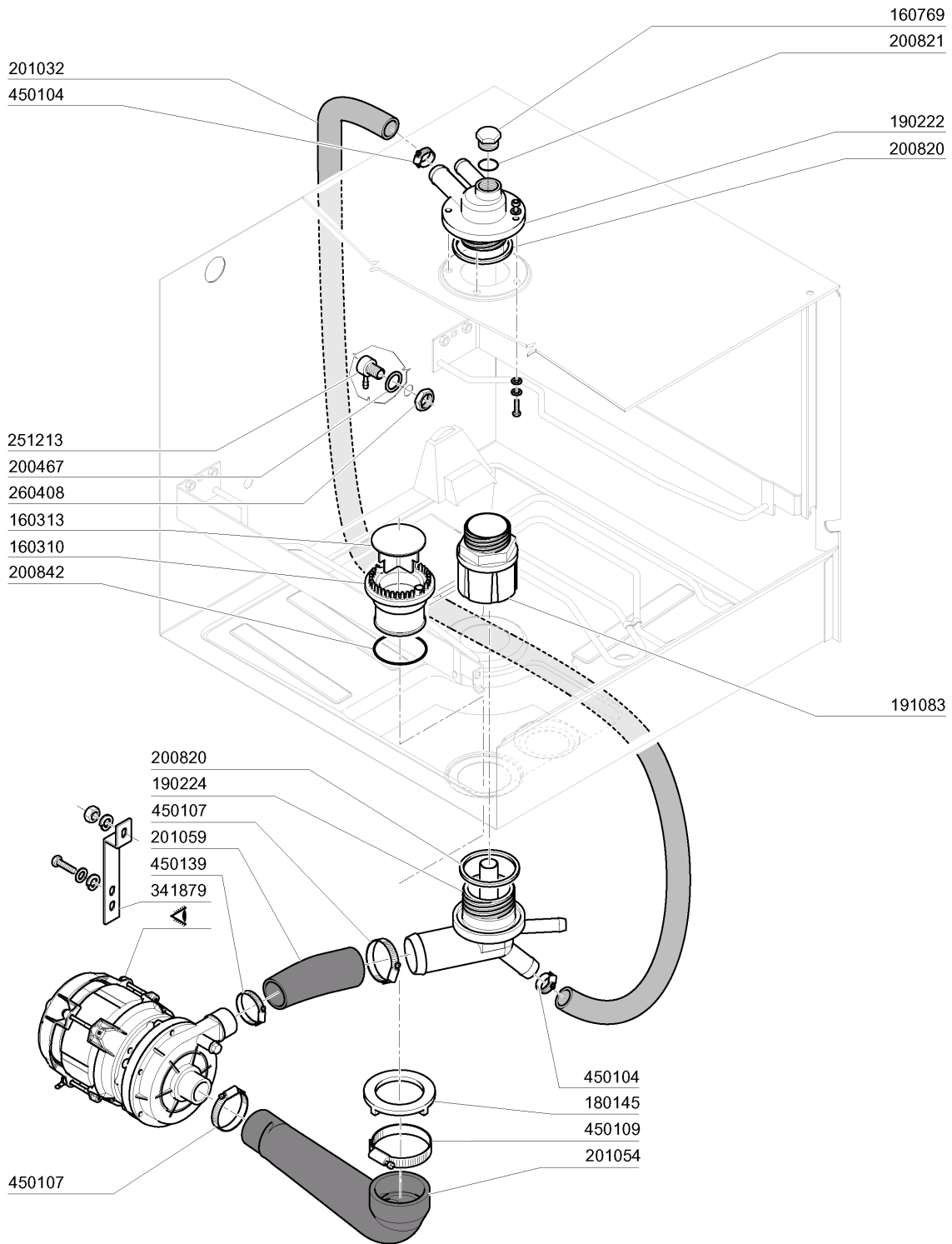

07 - 2010 M. S.

### 3 - Wash Column

CODE	DESCRIPTION
160310	INLET HOSE BHC
160313	VORTEX BREAKER
160769	PLUG F. UPPER WASH ARM SUPPORT
180145	NUT
190222	UPPER ARM SUPPORT
190224	LOWER TEE WASH-RINSE
191083	LOWER WASH ARM SUPPORT
200467	DUTRAL GASKET F. AIR TRAP
200820	O-RING151 46,99X5,33X57,6
200821	O-RING 2,62X20,63
200842	SEAL RING OR158 PB701 NITRILE
201032	OUTLET HOSE
201054	TANK INLET HOSE
201059	OUTLET HOSE
251213	INJECTIOR S/S FOR DETERGENT IN
260408	S/S NUTS D.12
341879	BRACKET FOR PUMP
450104	CLAMP FE ZN H=12,5 15-24
450107	CLAMP FE ZN 38-50 H=12,2
450109	CLAMP 50-65
450139	CLAMP 26-38 H=9

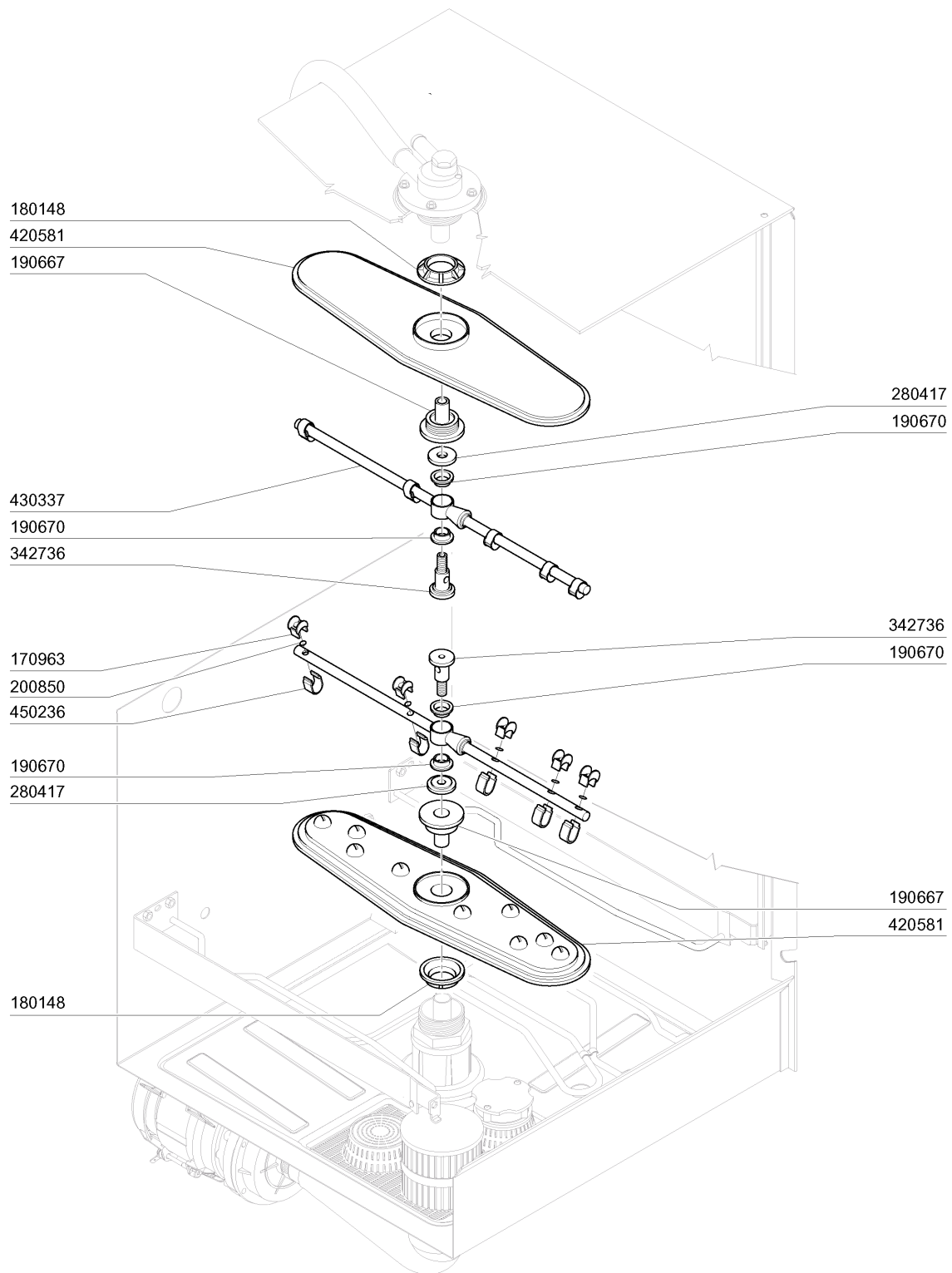

4 - Arm

CODE	DESCRIPTION
170963	RINSE JET X FC
180148	NUT
190667	BUSH
190670	BUSH
200850	O-RING
280417	RETAIN.LOCK NUT
342736	PIN
420581	ARM
430337	RINSE ARM BHC/1
450236	SPRING FOR WASHER 170963



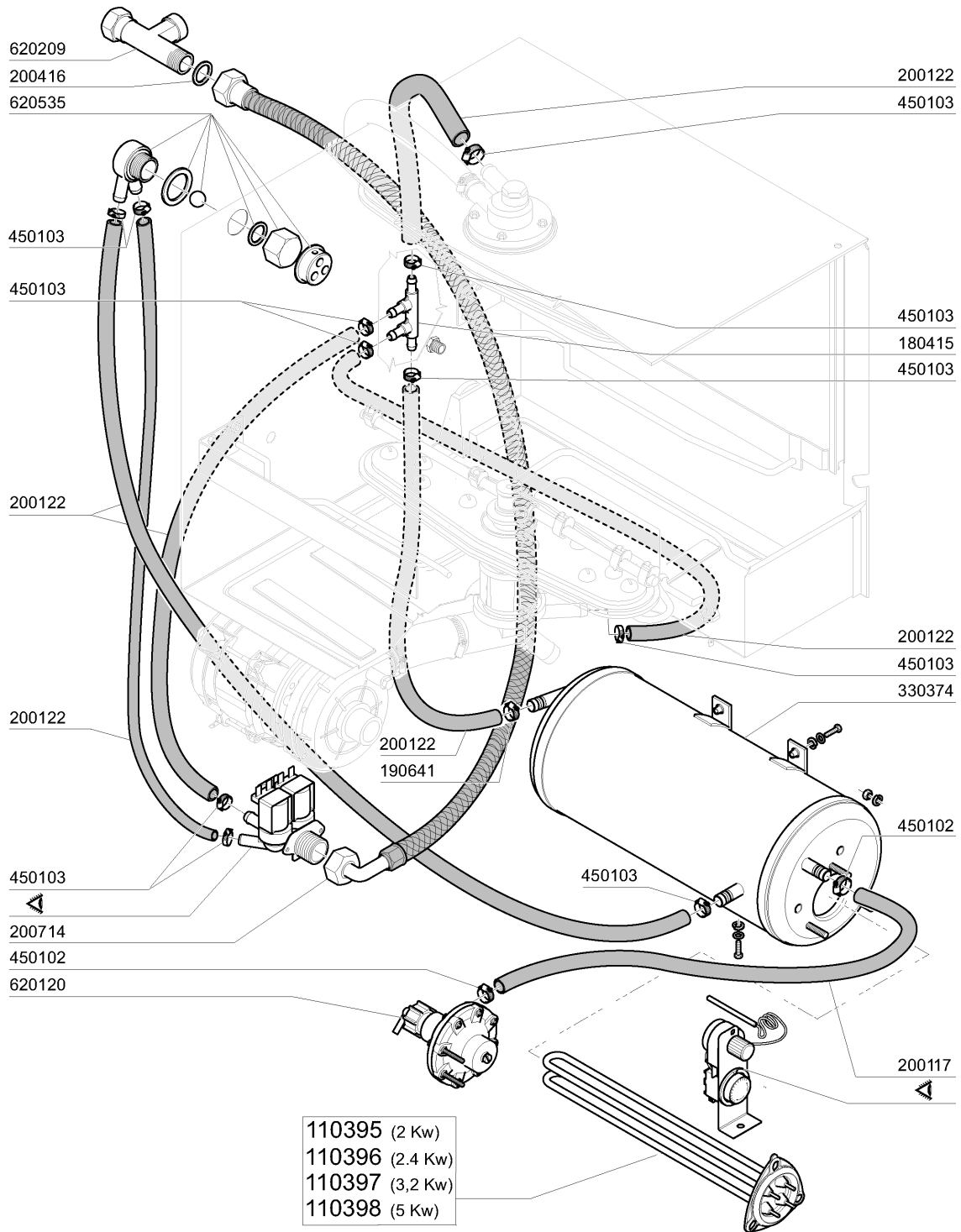

5 - Rinse

CODE	DESCRIPTION
110395	HEATER 2000W 230V/1
110396	HEAT. ELEMENT 2400W 230V/1
110397	HEATER 3200W 230V/1
110398	HEATER 5000W 230V/3
180415	TEE NIPPLE DOUBLE "T"
190641	BUSH FOR C95-155-165 RINSE ARM
200117	RUBBER HOSE 7X16
200122	HOSE 11X19
200416	GASKET D. 3/4"
200714	GLASSWASHER INLET HOSE
330374	BOOSTER BC
450102	CLAMP FE ZN 11-17 H=9
450103	CLAMP FE ZN. 13-20 H=9
620120	RINSE AID INJECTOR
620209	INLET WATER FILTER
620535	VACUUM BREAKER

## 6 - Thermostat/Solenoid Valve

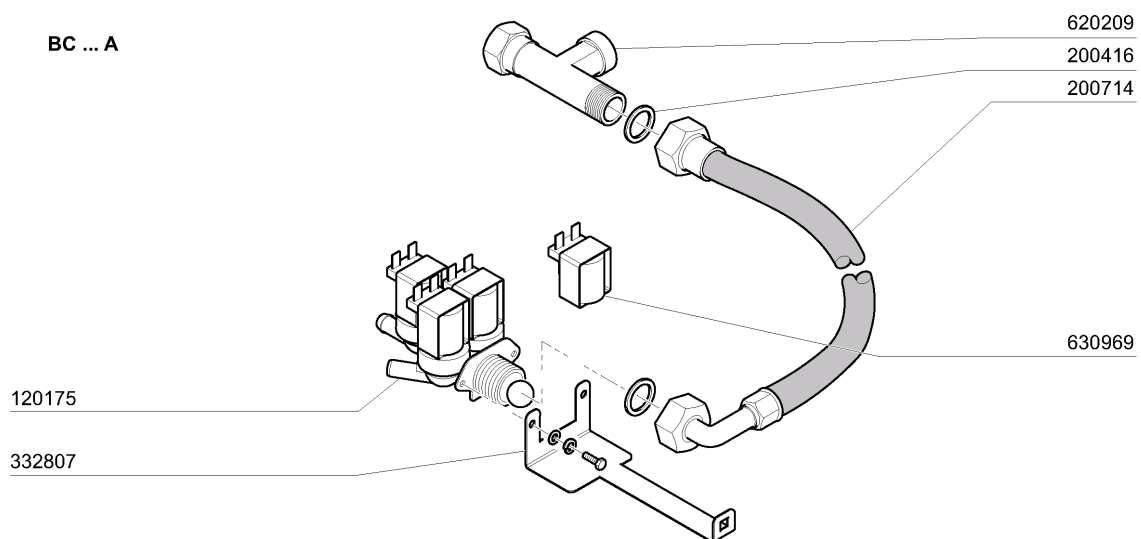
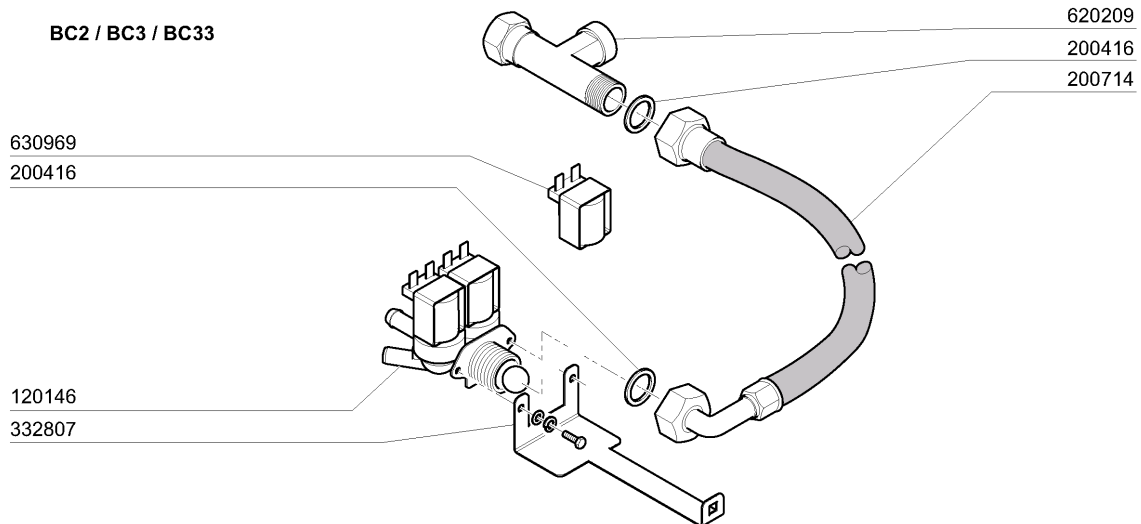
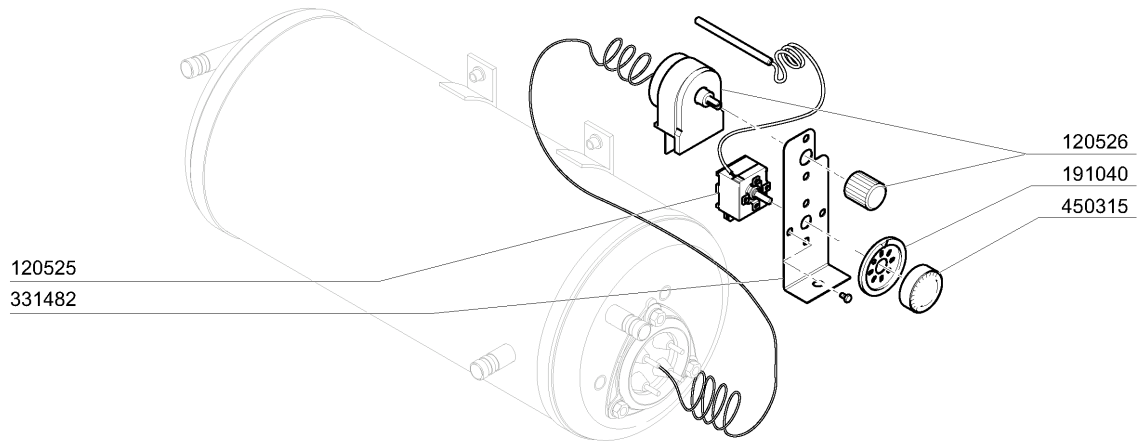

07 - 2010 M. S.

## 6 - Thermostat/Solenoid Valve

<b>CODE</b>	<b>DESCRIPTION</b>
120146	SOLENOID VALVE 180Ø TYPE 2 WAY
120175	SOLENOID VALVE 3 WAYS 180Ø
120525	BOOSTER THERMOSTAT 2 TEMPERAT.
120526	SAFETY THERMOSTAT 2POLES
191040	FRAME F.THERMOSTAT KNOB
200416	GASKET D. 3/4"
200714	GLASSWASHER INLET HOSE
331482	BRACKET FOR 2 THERMOST. B-F20
332807	BRACKET
450315	KNOB F. THERMOSTAT 90Ø
620209	INLET WATER FILTER
630969	COIL S4216 220/50HZ

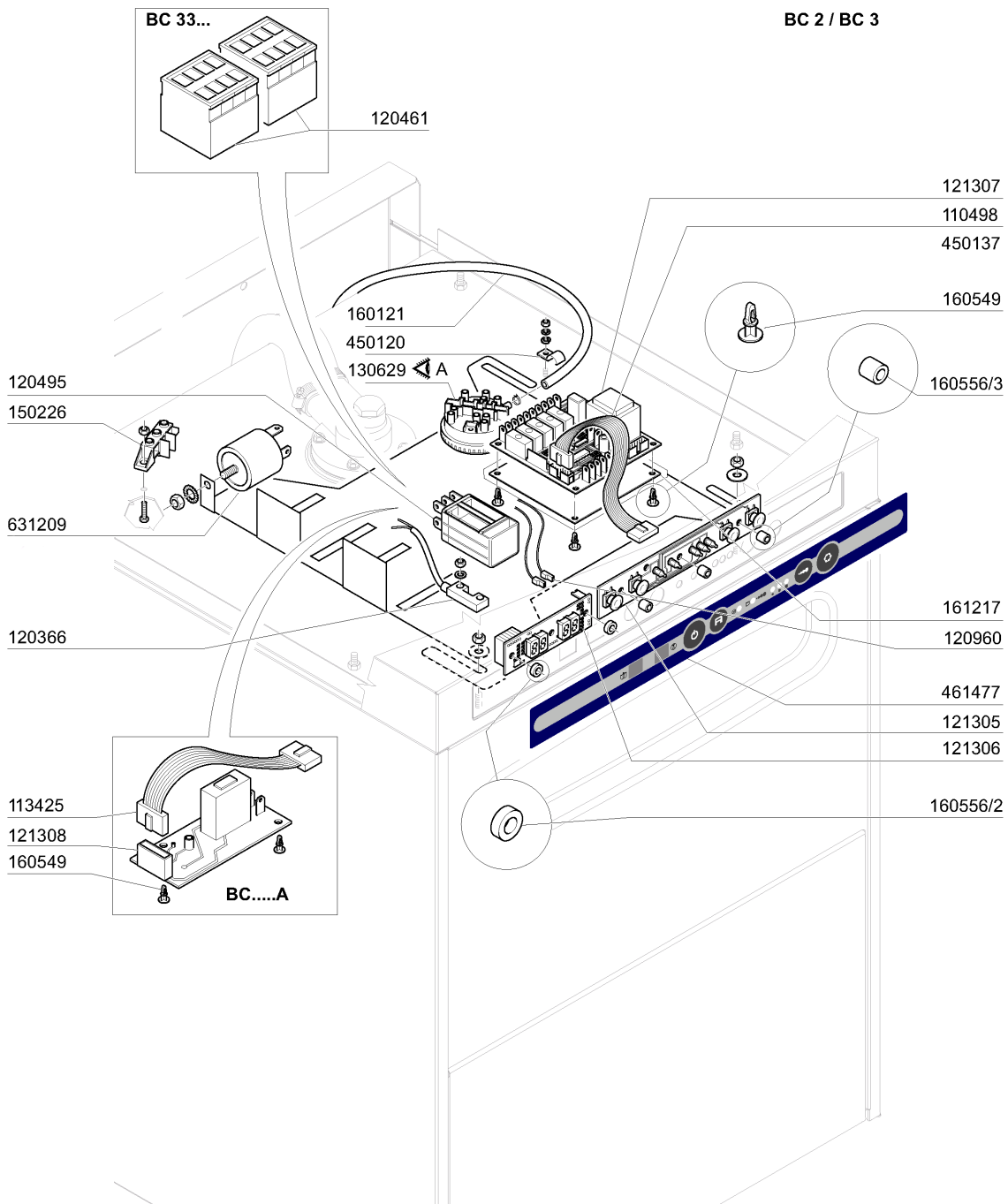

**7 - Control Box**

<b>CODE</b>	<b>DESCRIPTION</b>
110498	CABLE 500 MM
113425	FILI COLL.SCHEDA RIS.FREDDO BC
120366	MAGN.SENSOR
120461	CONTACTOR ABB B6-30-01 220V
120495	RELAY 16A 220V
120960	PROBE C-G
121305	CONTROL PCB
121306	PCB DISPLAY
121307	SOFTSTART PCB
121308	PCB
130629	PRESSURE SWITCH 1L30-12
150226	TERMINAL BLOCK
160121	HOSE EPDM D. 5 X 9
160549	SUPPORT
160556/2	SPACER FLIGHT
160556/3	DISTAN.D.4,3 X L.11,1(R912-07)
161217	PROTEZ.TIMER ELT.CON SOFTSTART
450120	ZINC CLAMP FOR HOSE D.7
450137	COLLAR CONNECTION WITH BASE 31
461477	PLATE BC2/3EA
631209	ANTI-NOISE FILTER

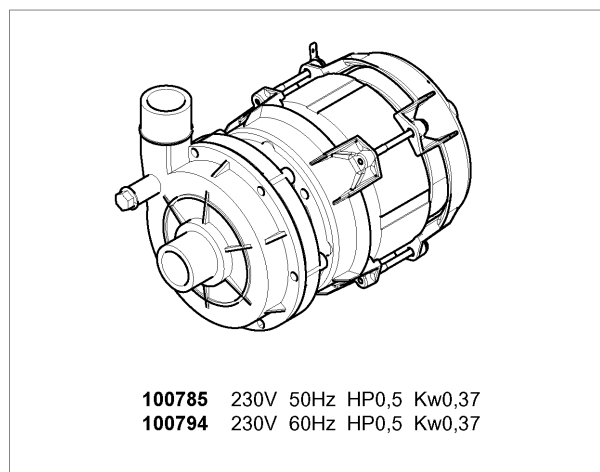
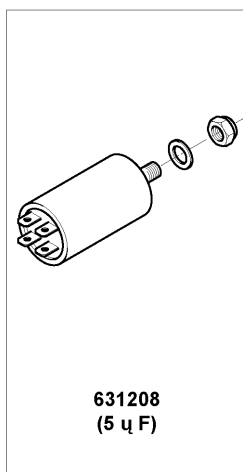
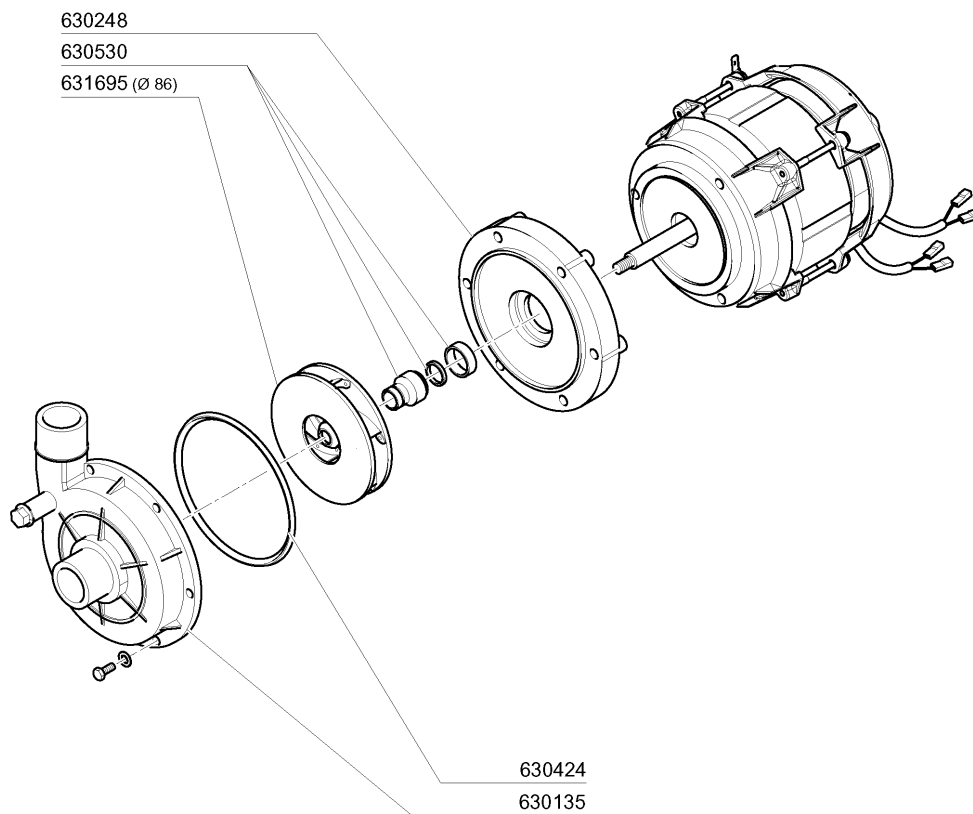

## 8 - Pump

<b>CODE</b>	<b>DESCRIPTION</b>
100785	PUMP LGB ZF140 0.5HP
100794	PUMP LGB ZF140 0.5HP 60HZ
630135	PUMP VOLUTE LGB 0,30HP ZF140
630248	PUMP COVER LGB 0,30HP ZF140
630424	PUMP GASKET LGB 0,3HP ZF140
630530	SEAL FOR PUMP LGB 0,3HP ZF140
631208	CONDENSER 5MF.450V
631695	PUMP IMPELLER 0,3HP LGB



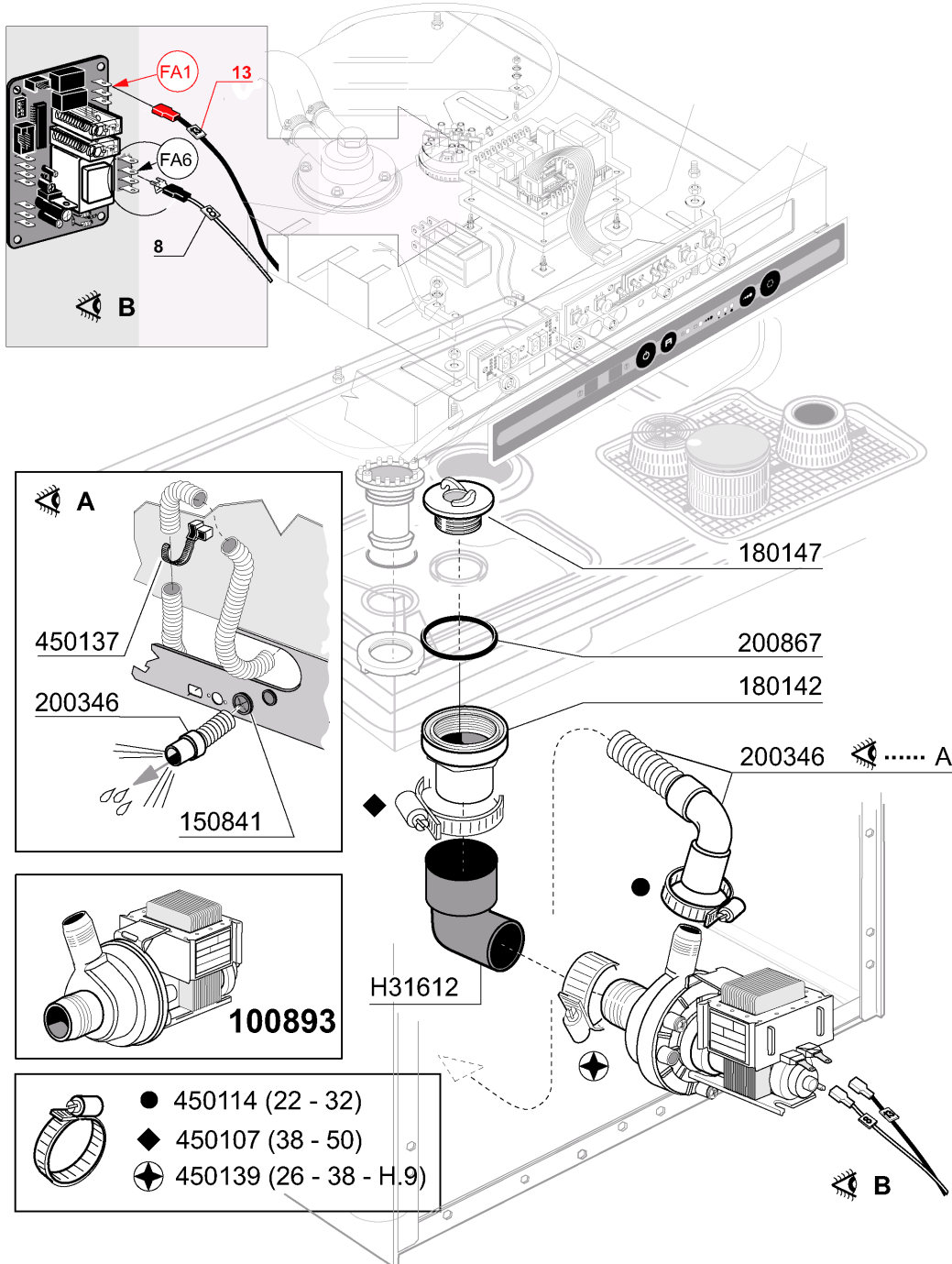

07 - 2010 M.S.

## 9 - Drain Pump

CODE	DESCRIPTION
100893	DRAIN PUMP 30W 230/50
150841	CABLE HOLDER
180142	CONNECTOR FOR DRAIN PUMP
180147	NUT
200346	DRAIN HOSE GLASSWASHER
200867	GASKET
450107	CLAMP FE ZN 38-50 H=12,2
450114	CLAMP FE ZN.22-32 H=12,2
450137	COLLAR CONNECTION WITH BASE 31
450139	CLAMP 26-38 H=9
H31612	HOSE FOR DRAIN PUMP

10 - Rinse aid injector

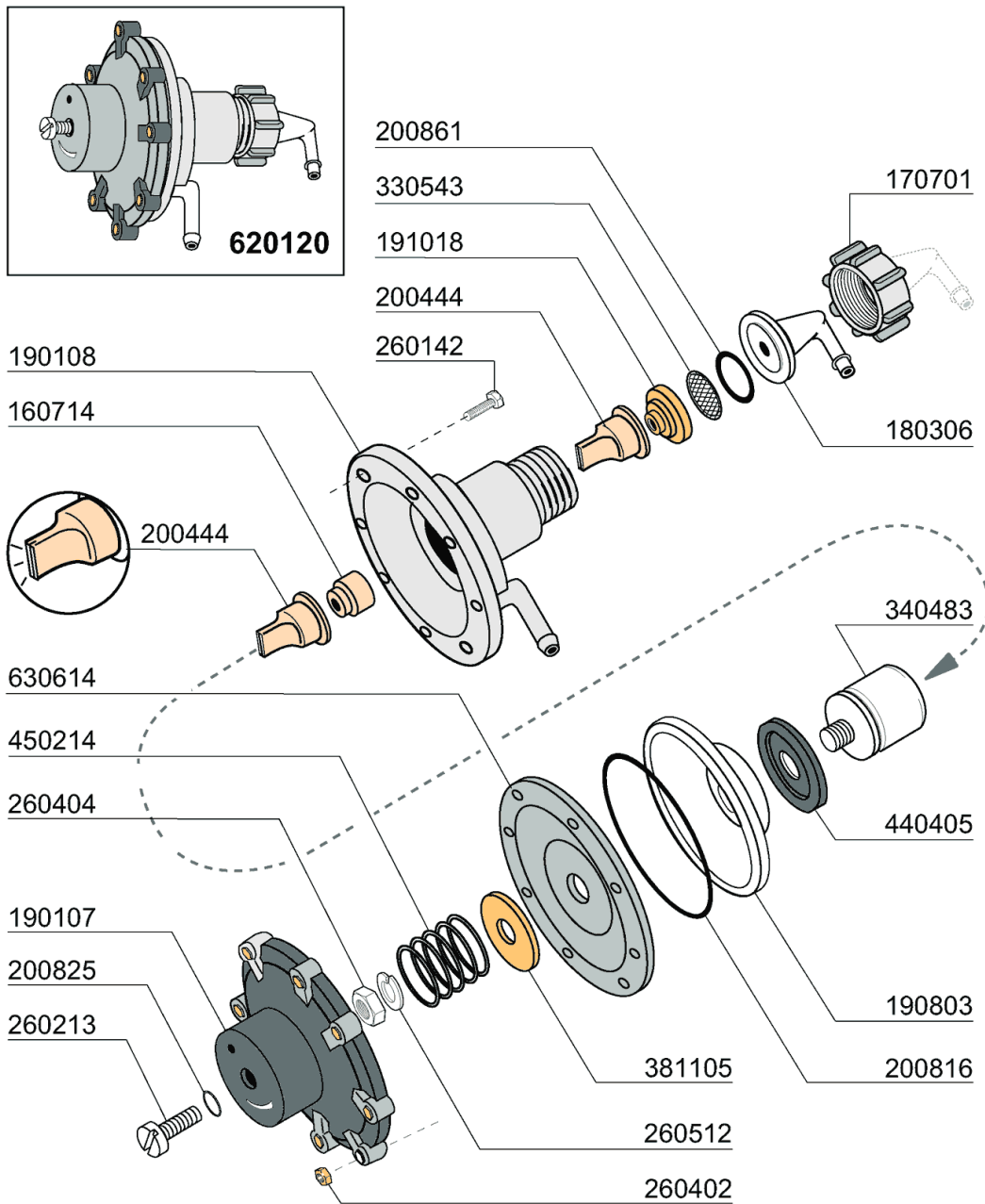

09 - 2007 | S. AG.

10 - Rinse aid injector

CODE	DESCRIPTION
160714	PLUG FOR RINSE AID INJECTOR MO
170701	LOCK NUT 1/2" F.INJECTOR
180306	NIPPLE F.RINSE AID INJECTOR
190107	COVER FOR RINSE AID DISPENSER
190108	VOLUTE FOR RINSE AID DISPENSER
190803	GASKET SUPPORT RING F.INJECT
191018	FILTER SUPPORT RINSE AID INJEC
200444	SUCTION VALVE RINSE INJECTOR
200816	O-RING 2,5X59,2X64,2 RINSE INJ
200825	O-RING 3X5X11 RINSE INJECTOR
200861	O-RING 14X18X2
260142	SCREW TE 4X16
260213	SCREW TCP 5X25
260402	STAINLESS STEEL NUT D4 UNI 55
260404	STAINLESS STEEL NUTS D6 UNI 55
260512	ST/ST GROWER WASHER D6
330543	FILTER RINSE AID INJECTOR D.17
340483	PISTON FOR RINSE AID DISPENSER
381105	DIAPHRAGME DISC
440405	GASKET FOR RINSE AID INJ.
450214	SPRING RINSE AID INJECTOR
620120	RINSE AID INJECTOR
630614	DIAPHRAGM RINSE INJECTOR

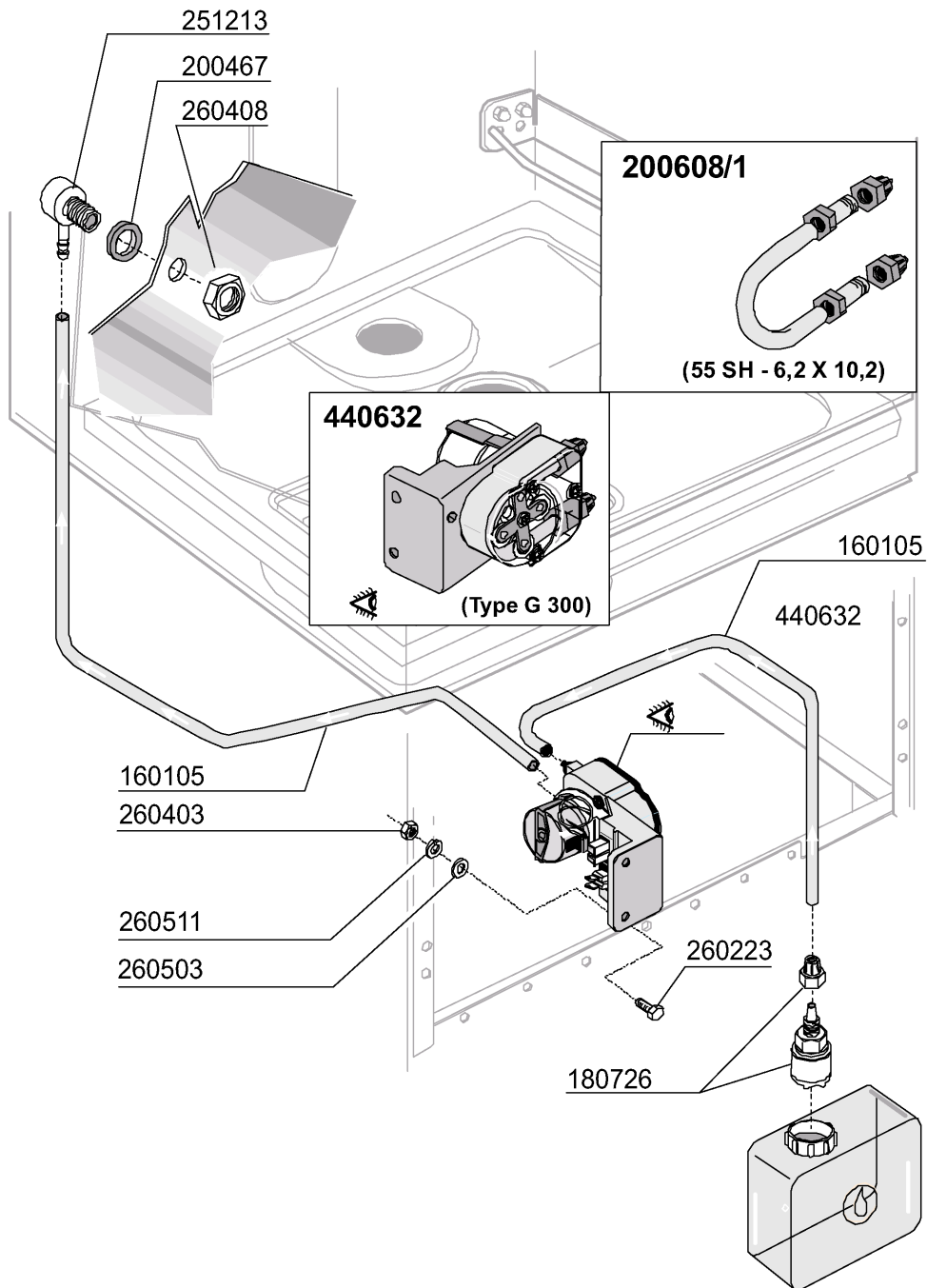

## 11 - Detergent Dispenser

CODE	DESCRIPTION
160105	INJECT.INLET HOSE D.6X4
180726	STREINER FOR RINSE AID INJECTO
200467	DUTRAL GASKET F. AIR TRAP
200608/1	HOSE FOR DISPENSER GERMAC G300
251213	INJECTIOR S/S FOR DETERGENT IN
260223	M5X12 MSH/HD SCREW SPECIAL S/S
260403	NUTS D.5
260408	S/S NUTS D.12
260503	STAINL.STEEL FLAT WASHER D5 UN
260511	GROWER WASHER D.5
440632	DETERGENT INJECTOR

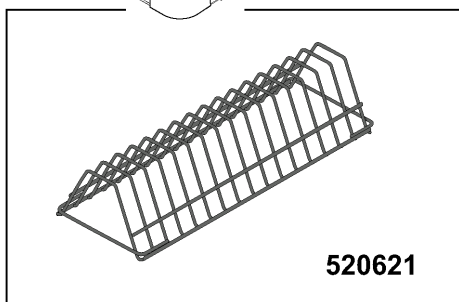
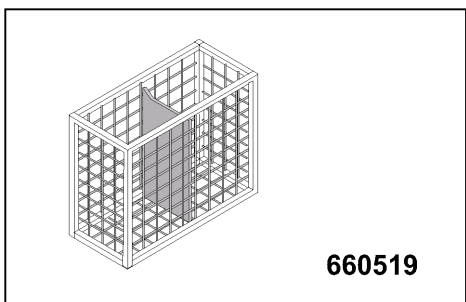
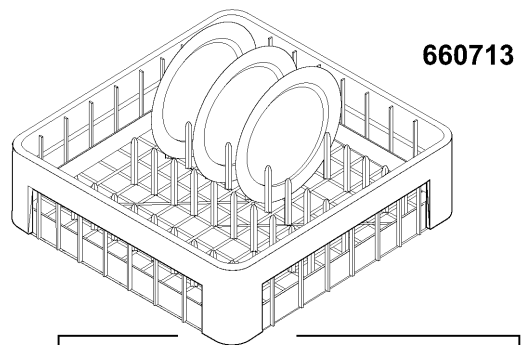
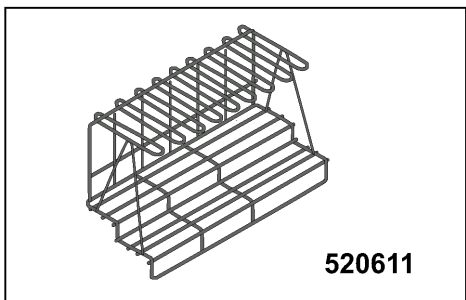
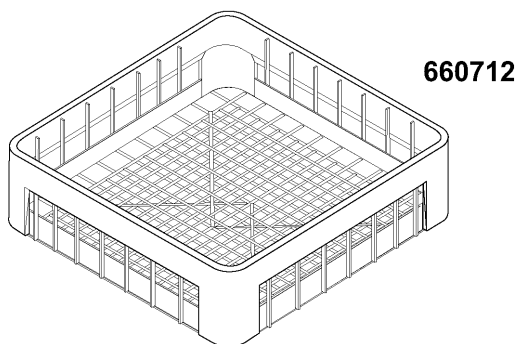
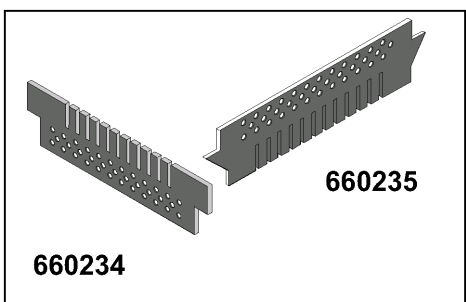
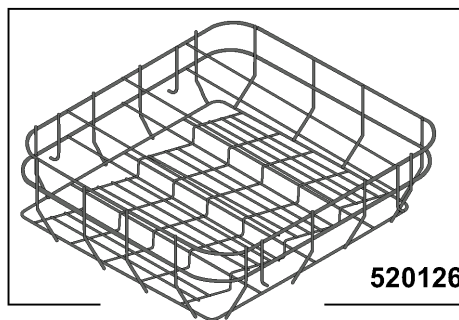
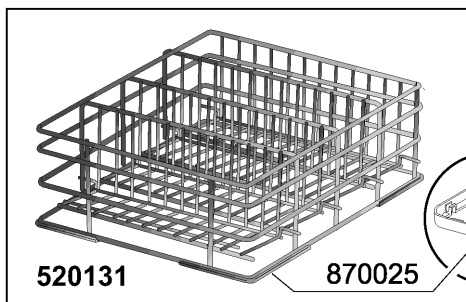

**12 - Rack**

<b>CODE</b>	<b>DESCRIPTION</b>
520126	GLASS INSERT (400X400)
520131	GLASS RACK 40X40 H270
520611	INSERT FOR CHAMPAGNE GLASSES
520621	SAUCERS INSERT
660234	UPPER INSERT FOR 16-25-36 GLAS
660235	LOWER INSERT FOR 16-25-36 GLAS
660519	2-PLACES CUTLERY HOLDER
660712	BASE RACK 400X400
660713	PLATE RACK 400X400
870025	IDLE SHAFTS N